

Rod Ends Series K - Extra Heavy Duty

Series GAXS

Rod Ends with male thread made from heat-treated steel, zinc plated and regreasable through a grease nipple in housing

Especially suitable for high pressure and tension loads

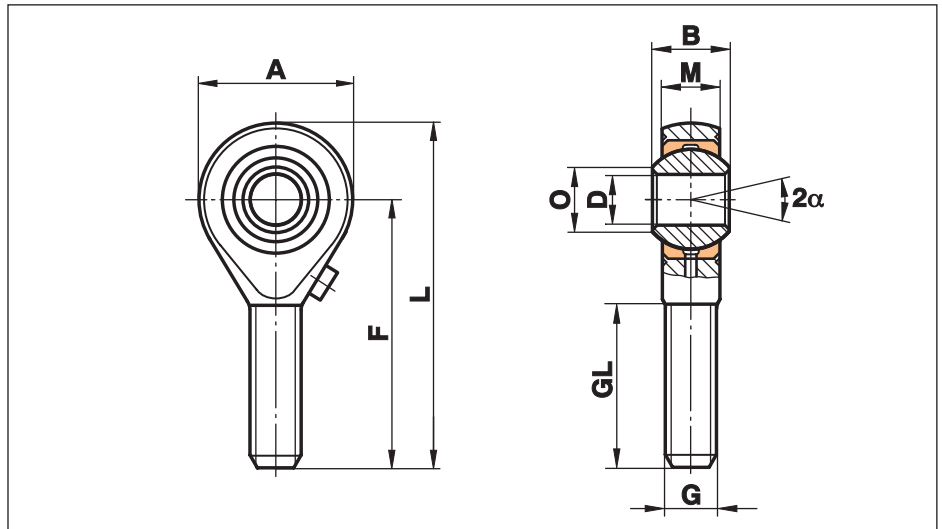

Size (D)	B	M	A	F	L	O	G	GL	Static load C ₀ kN	Dynamic load C kN	Limiting speed rev/min	Weight g
6	9	6,75	20	36	46	8,9	M 6	22	9,8	4,3	1500	20
8	12	9,00	24	42	54	10,4	M 8	25	19,5	7,1	1200	33
10	14	10,50	28	48	62	12,9	M 10	29	31,4	10,0	1000	56
12	16	12,00	32	54	70	15,4	M 12	33	42,0	13,5	860	87
14	19	13,50	36	60	78	16,8	M 14	38	57,0	17,0	750	129
16	21	15,00	42	66	87	19,3	M 16	40	67,5	21,5	660	189
18	23	16,50	46	72	95	21,8	M 18x1,5	44	81,5	26,0	600	267
20	25	18,00	50	78	103	24,3	M 20x1,5	47	93,5	31,5	540	348
22	28	20,00	54	84	111	25,8	M 22x1,5	51	114,0	38,0	500	443
25	31	22,00	60	94	124	29,6	M 24x2	57	135,0	47,0	440	600
30	37	25,00	70	110	145	34,8	M 30x2	71	184,0	64,0	370	1030

Materials:

Housing: Heat-treated steel to 42CrMo4, Aisi 4140, forged

Insert: Special high strength bronze to CuSn8

Ball: Bearing steel to 100Cr6, Aisi 52100, hardened, ground, polished

This series is also available sealed (see page 38) or with threaded bolt (see page 39).